

# LIGHT DUTY PERFORMANCE SYSTEMS

## FORD POWERSTROKE DIESEL 1999-UP

### HEAVY DUTY ALUMINIZED - O.E. FIT MUFFLER



#### FEATURES:

- 4" HI-FLOW SYSTEM
- HEAVY DUTY ALUMINIZED MUFFLER
- 4" ALUMINIZED TAIL PIPES
- OPTIONAL 4" IN & 5" OUT MUFFLER AVAILABLE
- OPTIONAL 5" TAILPIPE AVAILABLE

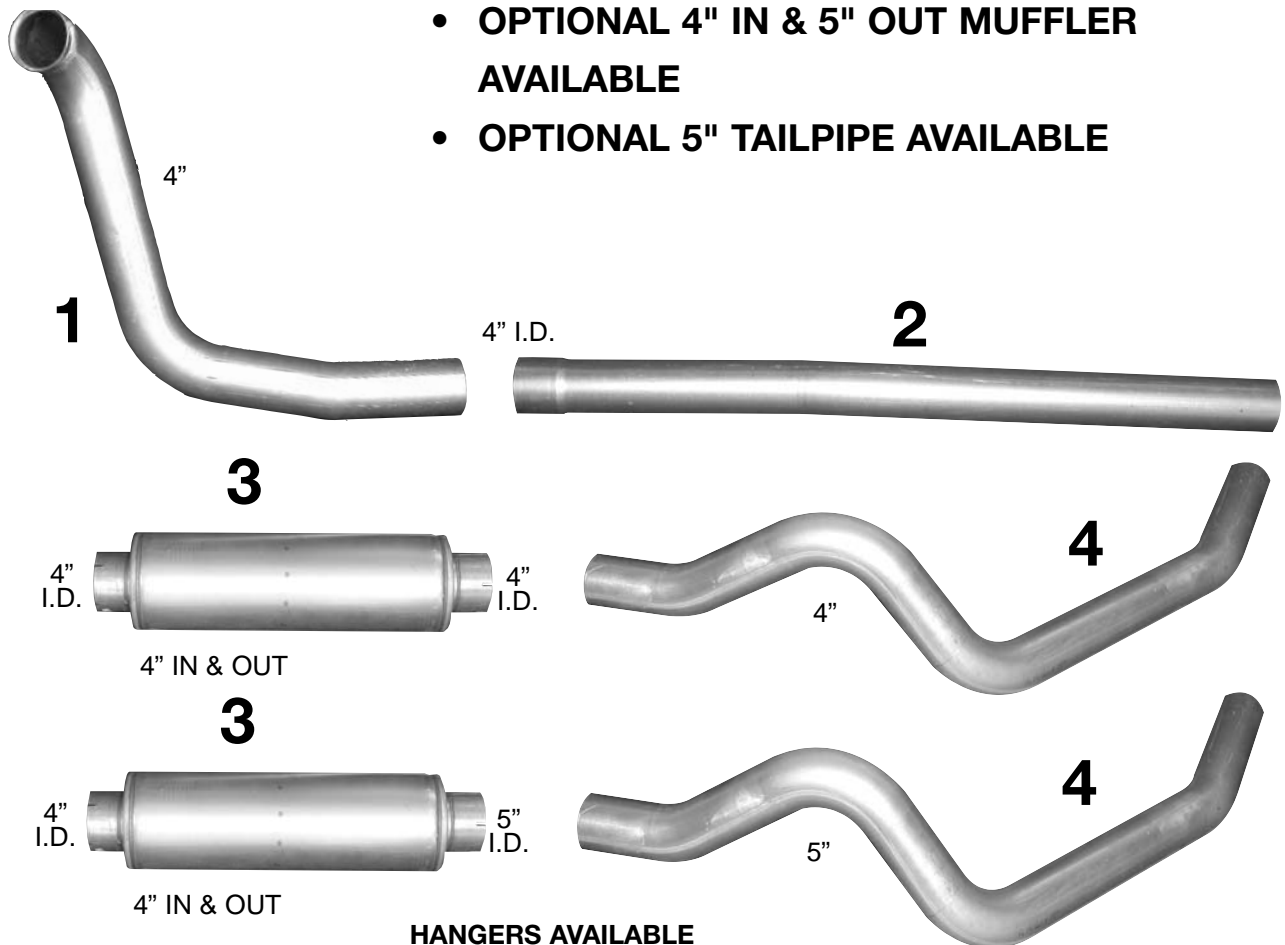

HANGERS AVAILABLE

1 - TURBO PIPE	2 - EXTENSION PIPE	3 - MUFFLER	4 - TAILPIPE
FORD400TURBO	FORD400EXTID/OD	7-0045	FLD400TP99 4"
SAME	SAME	CUS-101-02	FLD500TP99 5"

**AUTO-JET MUFFLER CORP.**

U.S. toll free 1-800-247-5391 • Fax 515-224-0727 • website: [www.auto-jet.com](http://www.auto-jet.com)  
 Canada toll free 1-866-229-3402 • Fax 519-455-1103 • website: [www.unitedmuffler.com](http://www.unitedmuffler.com)

**LD 1**

# DIESEL DODGE RAM PICK-UP

1994-2001 RAM 2500/3500 5.9L CUMMINS TURBO DIESEL



- PERFORMANCE SYSTEM**
- ALL 4" ALUMINIZED TUBE IN BACK OF TURBO
  - HEAVY DUTY-ALLWELDED-FREE FLOW MUFFLER

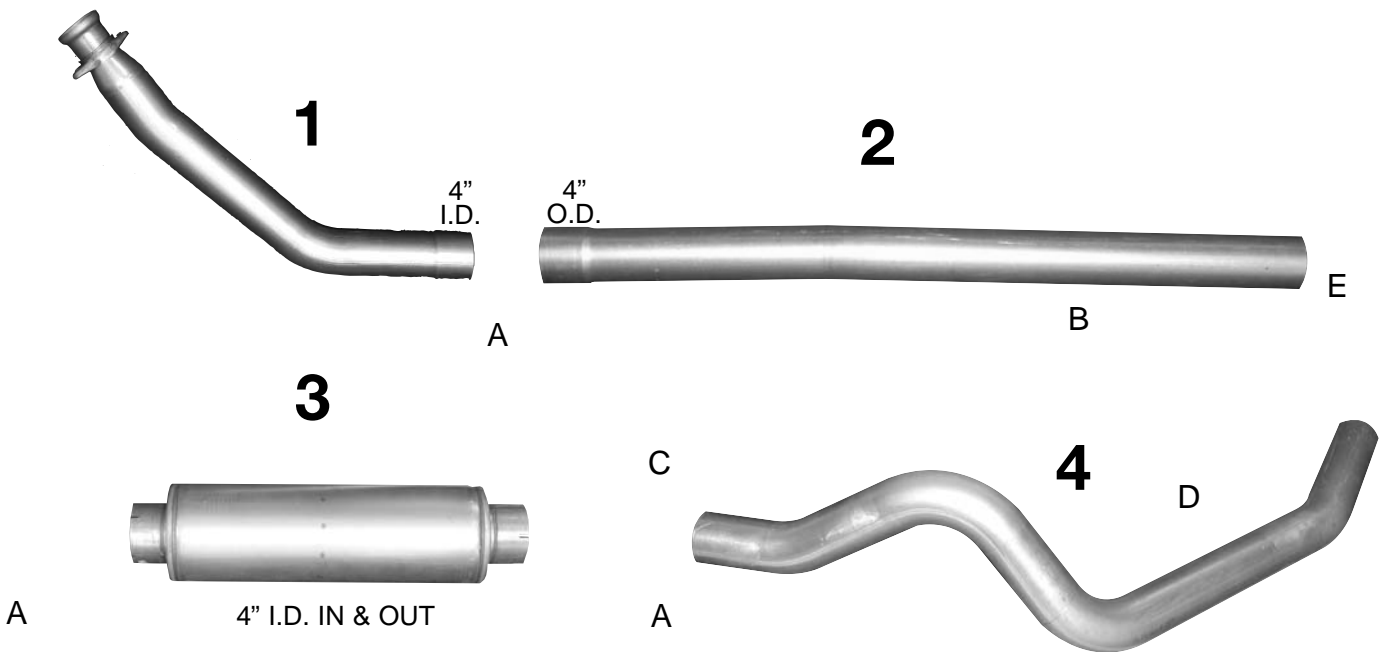

DESCRIPTION	1 - TURBO PIPE	2 - EXTENSION PIPE	3 - MUFFLER	4 - TAILPIPE
PART #	DODTURBO	DODPEXT	7-0045	DODPTP

## ACCESSORIES

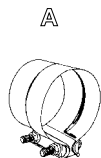

DESCRIPTION	A	E
	4" Satin Steel Clamp	Turndown
PART #	400SCPF	OPTIONAL SEE PAGE ACC7

## AUTO-JET MUFFLER CORP.

U.S. toll free 1-800-247-5391 • Fax 515-224-0727 • website: [www.auto-jet.com](http://www.auto-jet.com)  
 Canada toll free 1-866-229-3402 • Fax 519-455-1103 • website: [www.unitedmuffler.com](http://www.unitedmuffler.com)

# DIESEL HI-FLOW PICK-UP SYSTEMS

## 1993-UP DODGE CUMMINS DIESEL PICK-UPS WITH CONVERTER

AUTO-JET SPECIAL 3" ALUMINIZED TAILPIPE

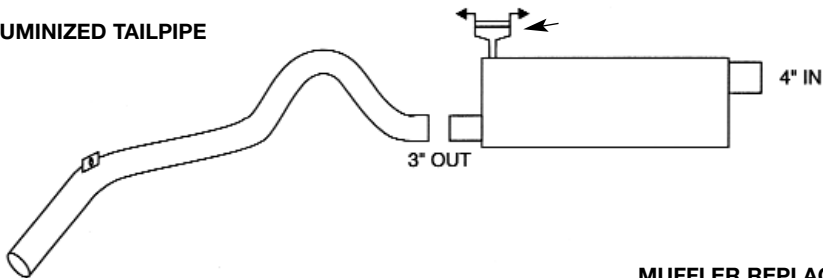

MUFFLER REPLACEMENT PIPE # DODMRPOE

	TAILPIPE (ALUMINIZED)	MUFFLER
1993-1996	54912	2156
1997-UP	54912	85-0050

## FORD 1985-UP 7.3 LITRE DIESEL F-250, F-350 2WD & 4WD

AUTO-JET SPECIAL 3" ALUMINIZED MANDREL BENT

NATURALLY  
ASPIRATED

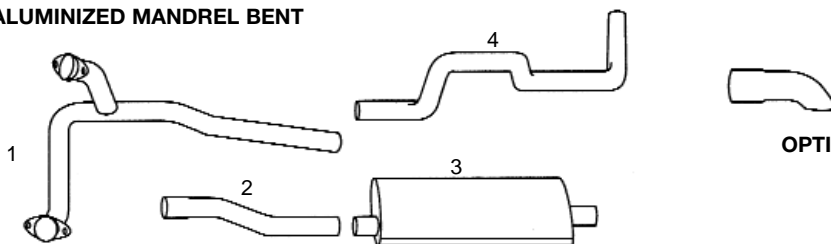

OPTIONAL CHROME TURN DOWN  
PART #: 3" - TD300C

POLISHABLE STAINLESS  
PART # TD300304

	MANIFOLD PIPE	2 - WHEEL BASE EXTENSION PIPE 3"	3 - MUFFLER	4 - TAIL PIPE 3" OR 3-1/2"
1985 - UP	73FY89	133" # 69FEX133	A-0015	3" FORD300TP
	SAME	155" # 69FEX155	A-0015	3" FORD300TP

## CHEVROLET/GMC 6.5 LITRE DIESEL TURBO PIPE

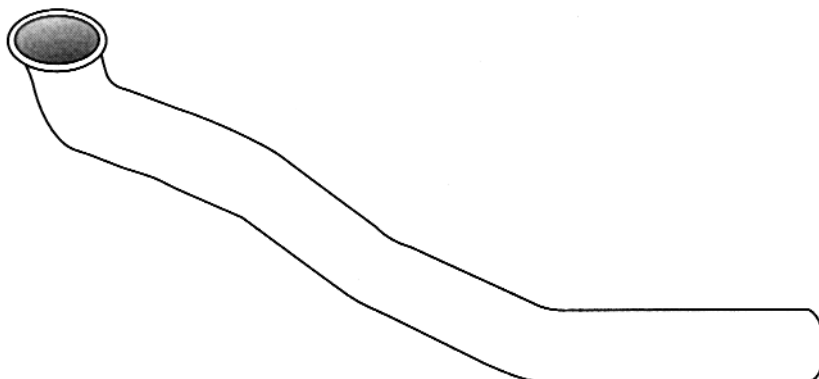

AUTO-JET PART NO.: GM65T  
APPLICATION: 1992-1994 MODELS WITH  
FACTORY TURBO OPTION

CAN BE MODIFIED FOR LATER MODELS

## AUTO-JET MUFFLER CORP.

U.S. toll free 1-800-247-5391 • Fax 515-224-0727 • website: [www.auto-jet.com](http://www.auto-jet.com)  
Canada toll free 1-866-229-3402 • Fax 519-455-1103 • website: [www.unitedmuffler.com](http://www.unitedmuffler.com)

# LIGHT DUTY ACCESSORIES

## TURN DOWNS

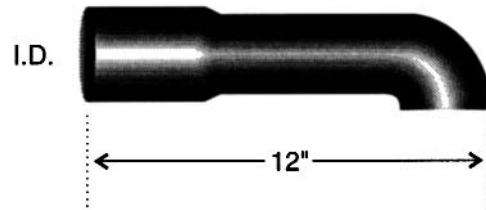

CHROME OR 304 POLISHABLE STAINLESS STEEL

SIZE - I.D.	3"	3-1/2"	4"	5" - 18" LONG
CHROME PART #	TD300C	TD350C	TD400C	TD500C
304 POLISHABLE STAINLESS PART #	TD300304	TD350304	TD400304	TD500304

## STAINLESS STEEL SLASH-CUT TIPS

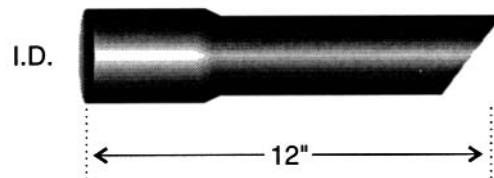

304 POLISHABLE STAINLESS STEEL

SIZE - I.D.	2-1/2"	3"	3-1/2"	4"
PART #	250TIPSS	300TIPSS	350TIPSS	400TIPSS

## ACCESSORIES

STAINLESS STEEL CLAMPS



U-BOLTS



DESCRIPTION	SIZE	SEAL CLAMPS	U-BOLTS
PART #	3"	300SCPF	U-300
PART #	3-1/2"	350SCPF	U-350
PART #	4"	400SCPF	U-400

## AUTO-JET MUFFLER CORP.

U.S. toll free 1-800-247-5391 • Fax 515-224-0727 • website: [www.auto-jet.com](http://www.auto-jet.com)  
 Canada toll free 1-866-229-3402 • Fax 519-455-1103 • website: [www.unitedmuffler.com](http://www.unitedmuffler.com)



# NEW SPECIAL MUFFLERS

## HEAVY-DUTY ALUMINIZED MUFFLERS FOR PICK-UPS & VANS

### FORD DIESEL "POWERSTROKE"

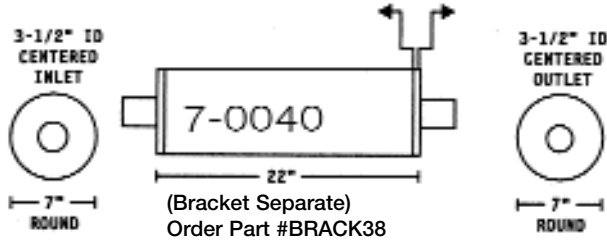

1994-1998 FORD POWERSTROKE  
O.E. REPLACEMENT MUFFLER

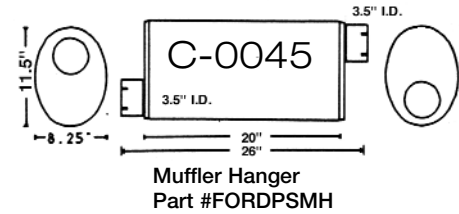

1999 & UP FORD POWERSTROKE  
O.E. REPLACEMENT MUFFLER

### DODGE DIESEL

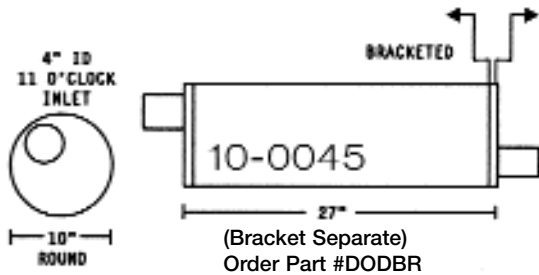

O.E. REPLACEMENT MUFFLER FOR  
1994-1996 DODGE DIESEL PICK-UP

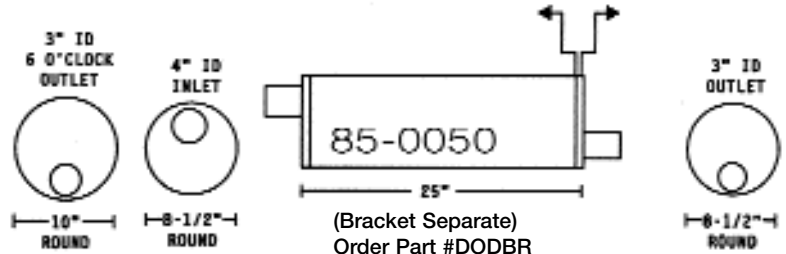

O.E. REPLACEMENT MUFFLER FOR  
1997 & UP DODGE DIESEL PICK-UP

### CHEVROLET - G.M.C.

**APPLICATION:**

G-30 VAN

**ENGINE:**

6.5 LITRE DIESEL

**YEAR:**

1998-UP

**PART NO.:**

65G300FL

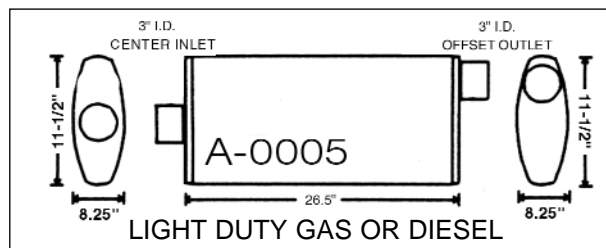

**APPLICATION:**

P-30 VAN

**ENGINE:**

350 C.I.

**YEAR:**

1996-UP

**PART NO.:**

C-0100

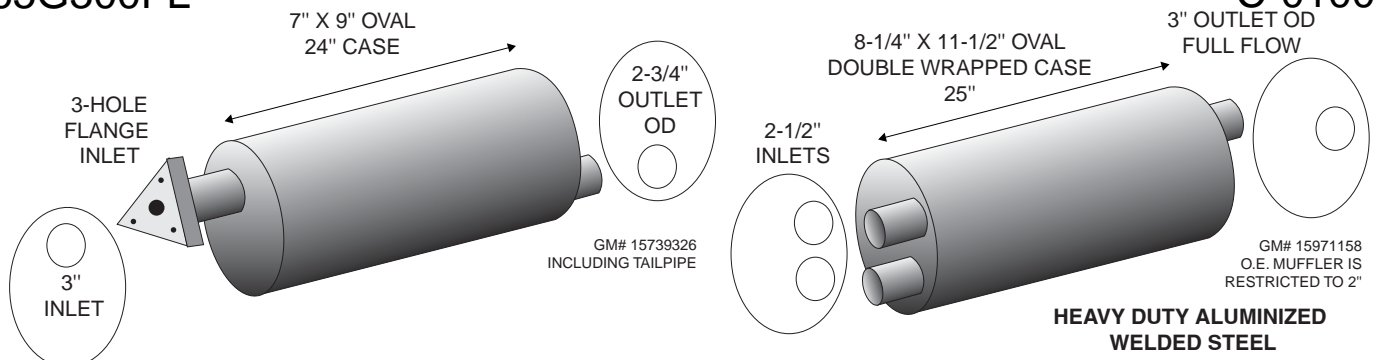

## AUTO-JET MUFFLER CORP.

U.S. toll free 1-800-247-5391 • Fax 515-224-0727 • website: [www.auto-jet.com](http://www.auto-jet.com)

Canada toll free 1-866-229-3402 • Fax 519-455-1103 • website: [www.unitedmuffler.com](http://www.unitedmuffler.com)

# DIESEL HI-FLOW PICK-UP SYSTEMS

## CHEVROLET/GMC 1987-90 350 C.I.D. & 454 C.I.D. TAIL PIPES

PICK-UP

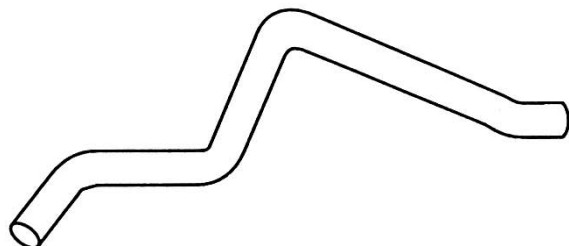

G-SERIES VAN

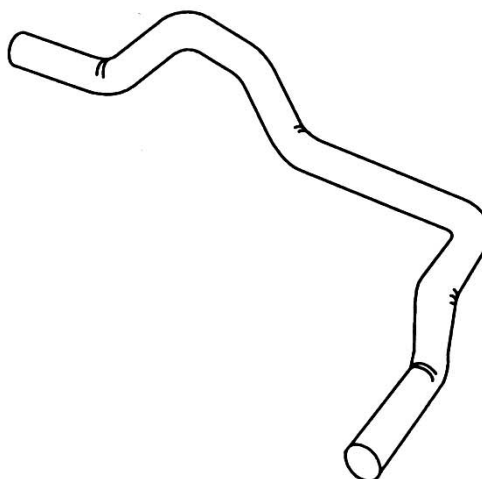

REPLACES DUAL TAIL PIPES OUT RIGHT CORNER

NOTE: 1 CONVERTER SYSTEM REQUIRES  
PART # G30MTPEXTENSION

TAIL PIPE 3"	TAIL PIPE 3" REPLACES OE SPLIT DESIGN
GM300TP	1 CONVERTER G30300TP1
MANDREL BENT ALUMINIZED	2 CONVERTERS G30300TP2

**Auto-Jet has 6 Mandrel Machines,  
bending 2" OD through 5" OD  
Aluminized & 304 Stainless Steel Tube  
in the U.S. & Canada**

**AUTO-JET MUFFLER CORP.**

U.S. toll free 1-800-247-5391 • Fax 515-224-0727 • website: [www.auto-jet.com](http://www.auto-jet.com)  
Canada toll free 1-866-229-3402 • Fax 519-455-1103 • website: [www.unitedmuffler.com](http://www.unitedmuffler.com)

**LD 6**