

CHEVROLET/GMC EXHAUST SYSTEMS

1998-UP 454-502 C.I. GAS Series 60 70 95

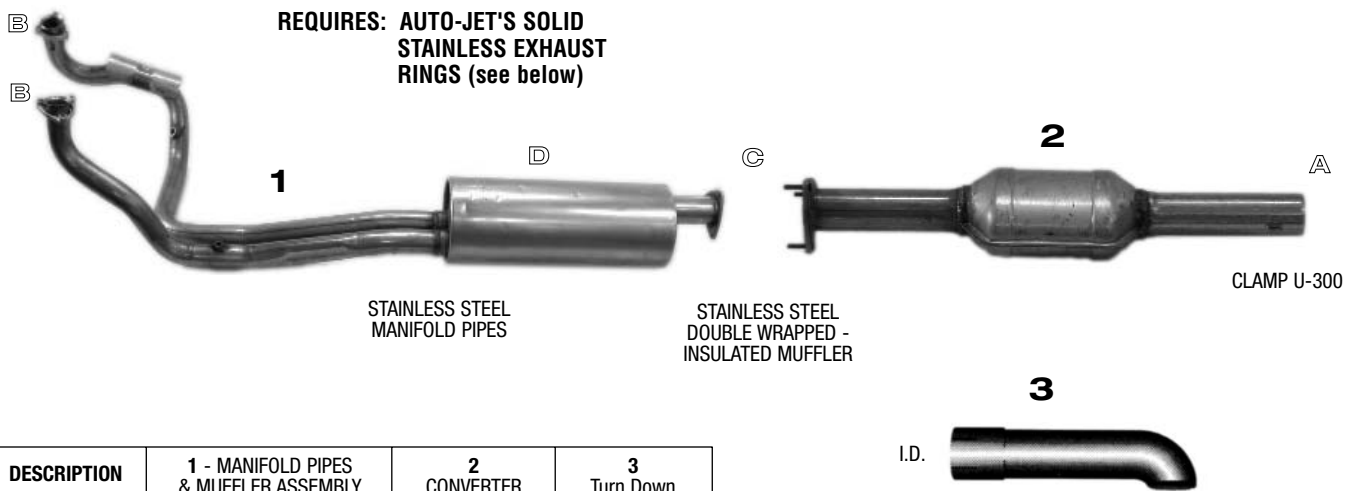

DESCRIPTION	1 - MANIFOLD PIPES & MUFFLER ASSEMBLY	2 CONVERTER	3 Turn Down
PART #	GM454ASSY	GMCONV454	TD300ID

ACCESSORIES

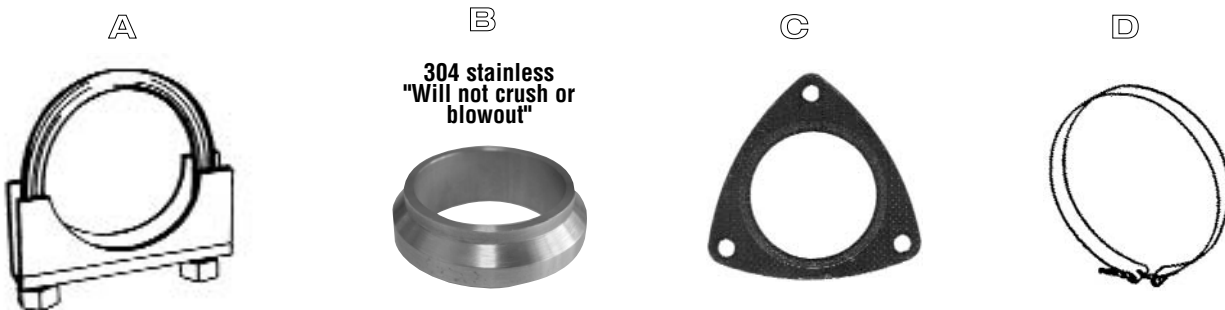

DESCRIPTION	A CLAMPS	B EXHAUST RINGS	C GASKET	D MUFFLER HANGERS
PART #	U-300	454ER304	GMGS3HOLE	GM875MH

AUTO-JET MUFFLER CORP.

U.S. toll free 1-800-247-5391 • Fax 515-224-0727 • website: www.auto-jet.com
 Canada toll free 1-866-229-3402 • Fax 519-455-1103 • website: www.unitedmuffler.com

GMC - CHEVROLET EXHAUST SYSTEMS

1997-UP GM 40-50 SERIES KODIAK TOPKICK CHASSIS 6.5 LITRE TURBO DIESEL

POPULAR ON MID-BUS AND OTHERS

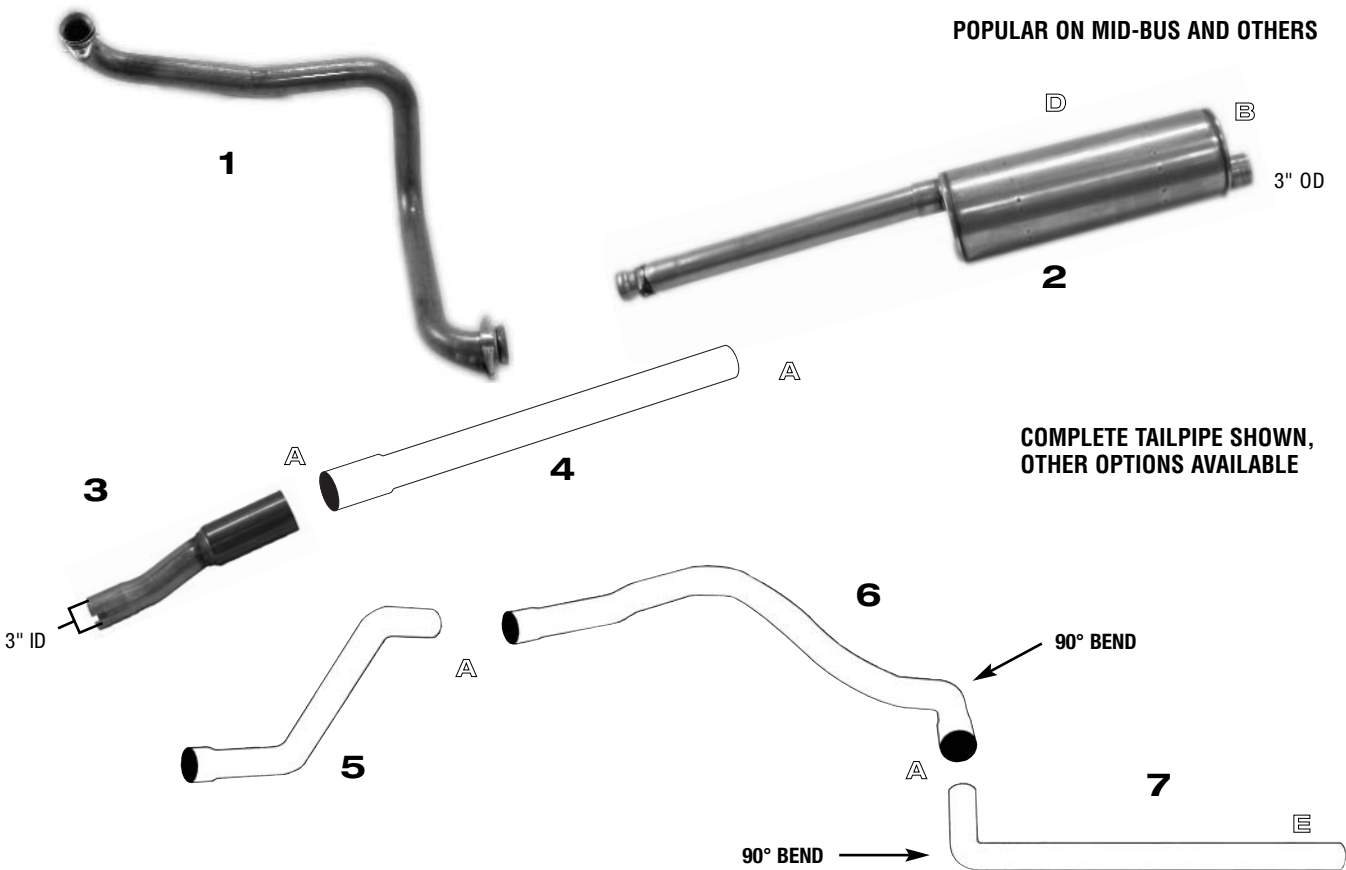

DESCRIPTION	1 TURBO PIPE	2 MUFFLER	3 FRONT PIPE	4 INT. PIPE	5 FRONT OVERAXLE	6 REAR OVERAXLE	7 TAIL PIPE
PART #	GMKOD65T	85-0016	GM454FP	CV400STPID	CVFOA97	CVOA94	CVTP94

ACCESSORIES

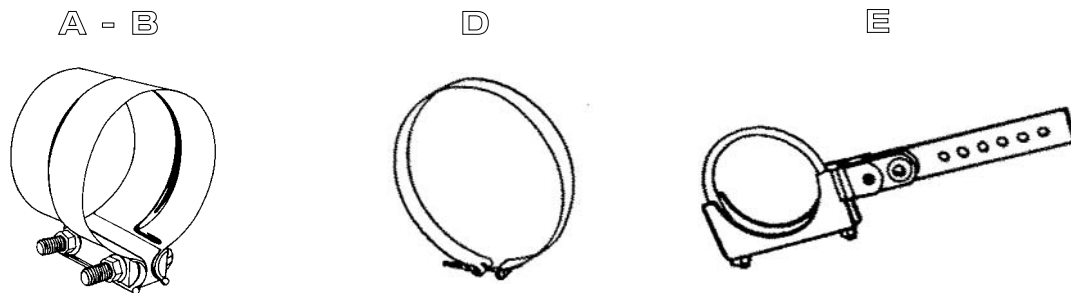

DESCRIPTION	OVERAXLE ACCESSORIES		D MUFFLER HANGERS	E TAILPIPE HANGERS
PART #	A 400SCPF	B 300SCPF	GM875MH	GMHGR4

AUTO-JET MUFFLER CORP.

U.S. toll free 1-800-247-5391 • Fax 515-224-0727 • website: www.auto-jet.com
Canada toll free 1-866-229-3402 • Fax 519-455-1103 • website: www.unitedmuffler.com

GM 2

CHEVROLET/GMC EXHAUST SYSTEMS

1990-98 TOPKICK/KODIAK C6/C7 WITH 6.6L CAT 3116 ENGINE

SINGLE VERTICAL SYSTEM

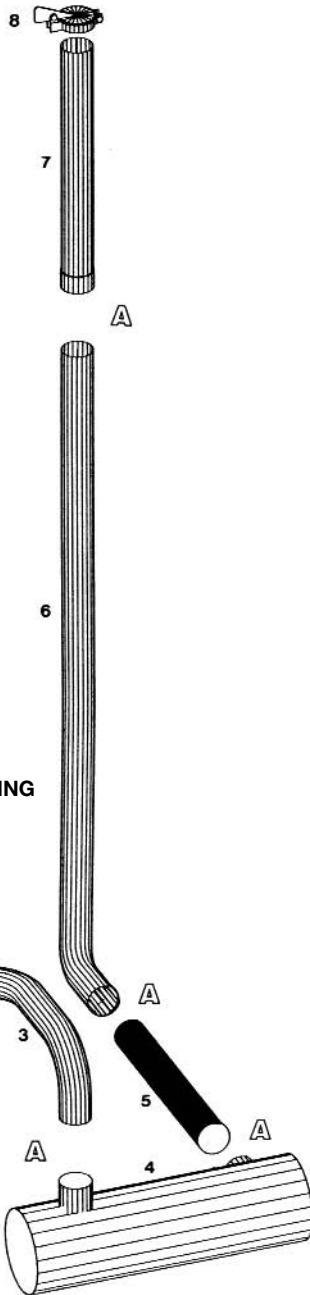

NOTE:
STACK RIGHT (PASSENGER'S SIDE) SHOWN.

FOR TURBO PIPE WITH PYROMETER FITTING
ORDER PART # 3116 KODTPY

ACCESSORIES

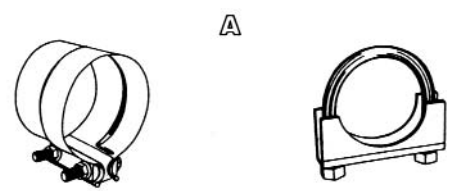

DESCRIPTION	CLAMPS A	
PART #	400SCPF	U-400

DESCRIPTION	1 V-CLAMP	2 TURBO PIPE	3 INTERMEDIATE PIPE	4 MUFFLER	5 FLEX	6 INTERMEDIATE STACK	7 STACK	8 RAIN CAP
STACK RIGHT #	3116VCL	3116KODT	3116EPKOD	86727 or 86725 SEE PAGE GM 16	FLEX40024	STAK470GM	STAK364	RC400
STACK LEFT #	SAME	SAME	SAME	86756				

AUTO-JET MUFFLER CORP.

U.S. toll free 1-800-247-5391 • Fax 515-224-0727 • website: www.auto-jet.com
 Canada toll free 1-866-229-3402 • Fax 519-455-1103 • website: www.unitedmuffler.com

CHEVROLET/GMC EXHAUST SYSTEMS

1983-88 C-60 & 70 3208 CATERPILLAR TURBO

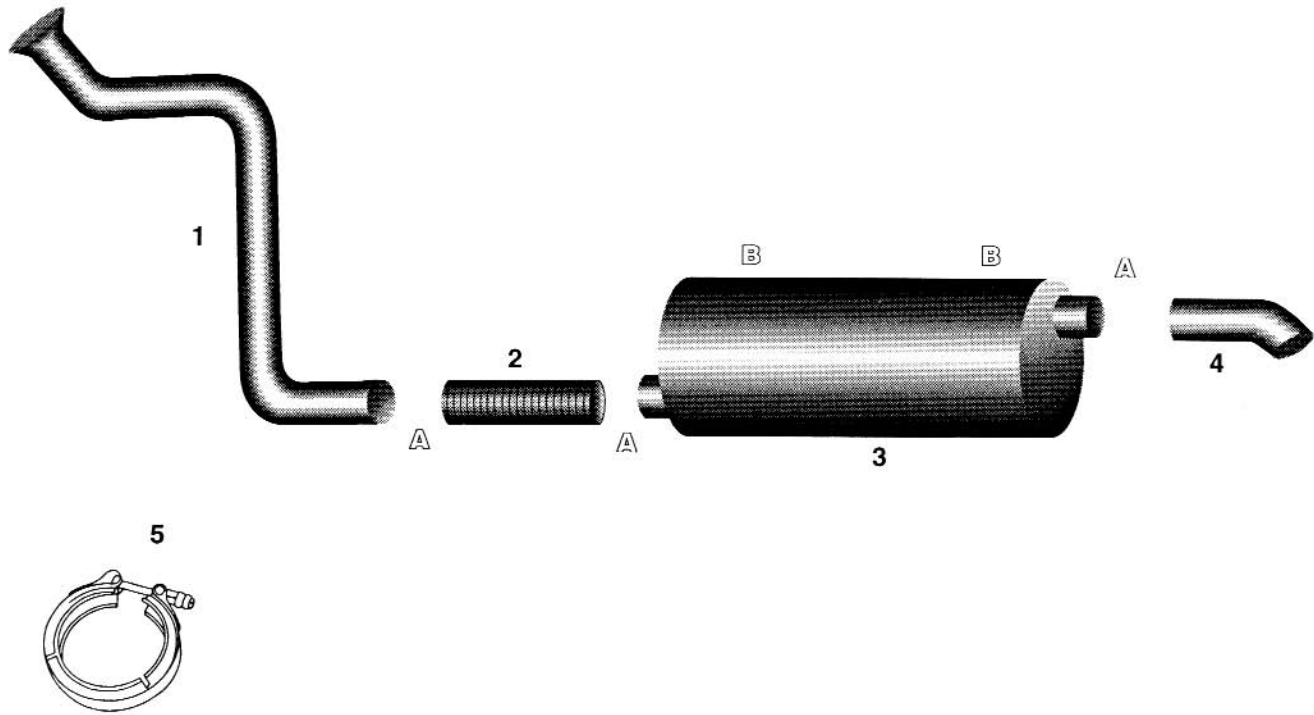

DESCRIPTION	1 TURBO PIPE	2 FLEX	3 MUFFLER	4 TURN DOWN	5 V-CLAMP
PART #	3208TC60	FLEX40018OD	C-0010	TD400	3208VCLT

ACCESSORIES

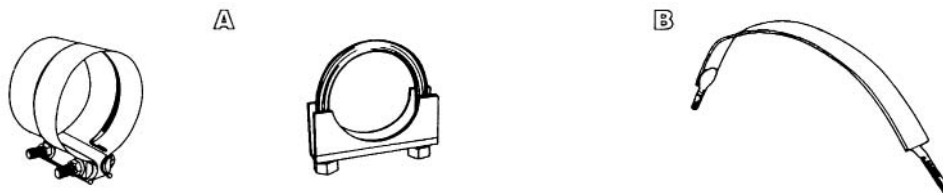

DESCRIPTION	CLAMPS A		MUFFLER STRAP B
PART #	400SC	U-400	GMOVSTRAP

AUTO-JET MUFFLER CORP.

U.S. toll free 1-800-247-5391 • Fax 515-224-0727 • website: www.auto-jet.com
 Canada toll free 1-866-229-3402 • Fax 519-455-1103 • website: www.unitedmuffler.com

GM 4

CHEVROLET/GMC C-50-60-70-80

1990-UP CHEV. - GMC 3116 CATERPILLAR ENGINE

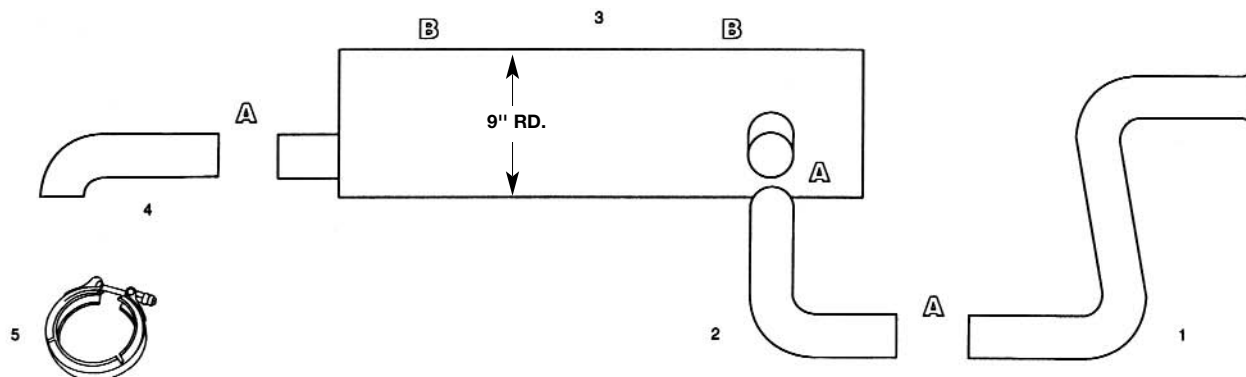

DESCRIPTION	1 - TURBO PIPE	2 - ELBOW	3 - MUFFLER	4 - TURN DOWN	5 - V-VLAMP
PART #	CV3116T	CV3116EL	CV400400	TD400	3116VCL

1990-98 TOPKICK/KODIAK C6, C7 WITH 6.6L CAT 3116 ENGINE

SINGLE HORIZONTAL SYSTEM

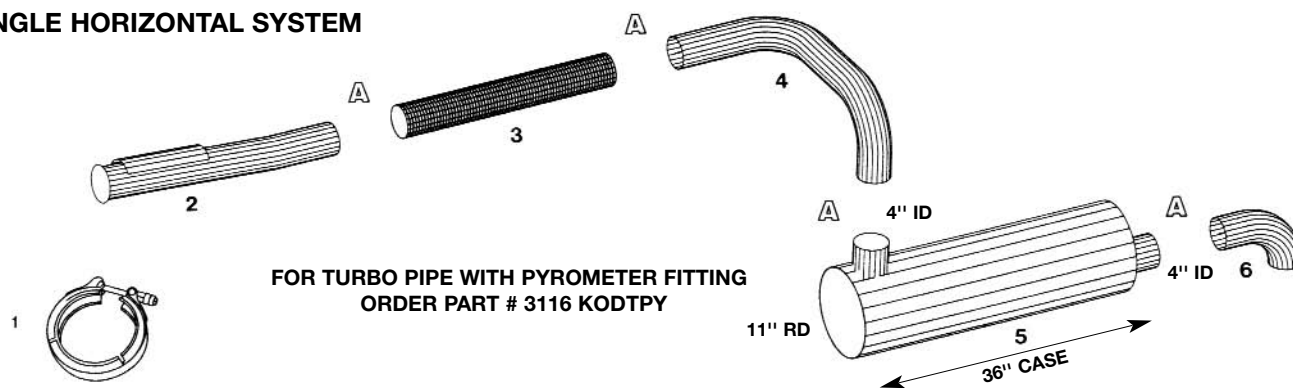

DESCRIPTION	1 V-CLAMP	2 TURBO PIPE	3 FLEX	4 INTERMEDIATE PIPE	5 MUFFLER	6 TAIL PIPE
PART #	3116VCL	3116KODT	FLEX40012	3115EPKOD	72486L	TD400

ACCESSORIES

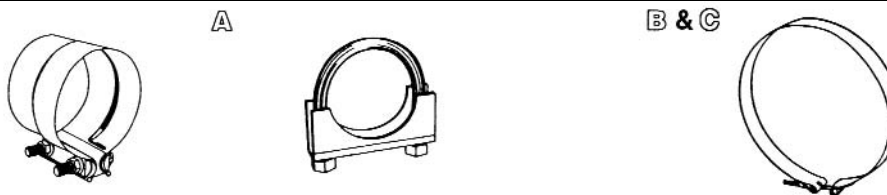

DESCRIPTION	CLAMPS		MUFFLER HANGER	
	A		B	C
PART #	400SC	U-400	9MHTORCA	1100MH

AUTO-JET MUFFLER CORP.

U.S. toll free 1-800-247-5391 • Fax 515-224-0727 • website: www.auto-jet.com
 Canada toll free 1-866-229-3402 • Fax 519-455-1103 • website: www.unitedmuffler.com

CHEVROLET/GMC C-50-60-70-80

1980-87 SERIES 8.2 LITRE NATURALLY ASPIRATED

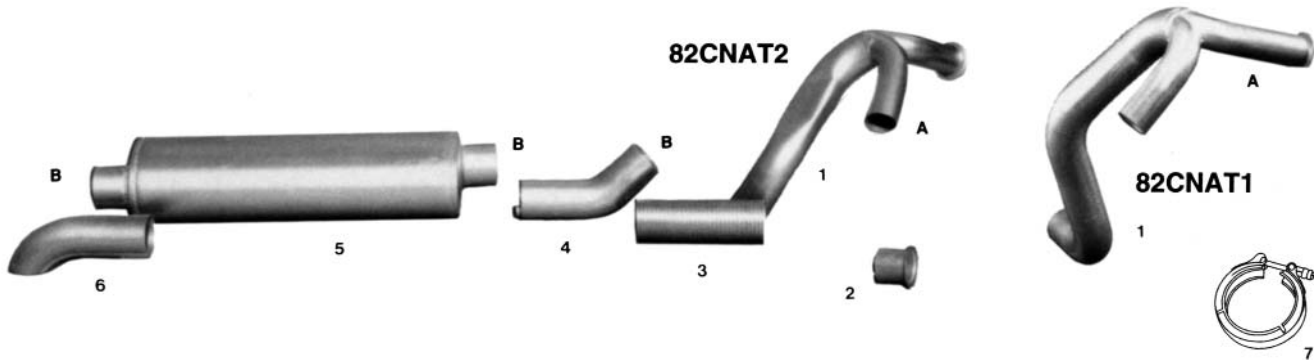

	1 - Y PIPE	2 - Y PIPE RIGHT	3 - FLEX	4 - ELBOW	5 - MUFFLER	6 - TURN DOWN	7 - V-CLAMP
STYLE 1	82CNAT1 OE# 2088280 2090694	82FLARE	82CFLEX18OD	N/R	C-0020 (OVAL)	TD400	82VCLNA
STYLE 2	82CNAT2 OE# 2046392	82FLARE	82CFLEX28	82CNAEL	C-0020 (OVAL)	TD400	82VCLNA

1980-UP CHEVROLET-GMC 8.2 LITRE, TURBO

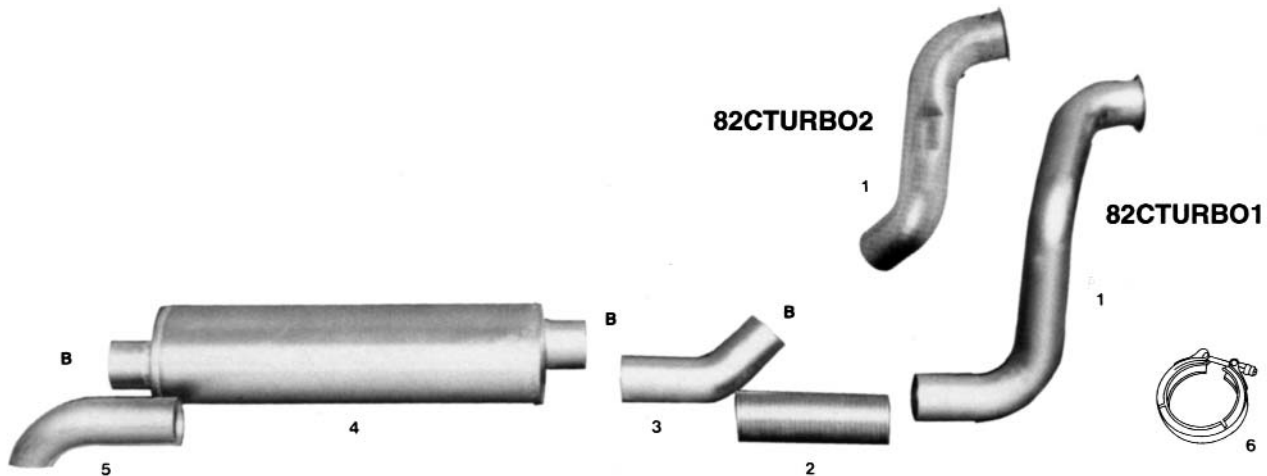

	1 - TURBO PIPE	2 - STAINLESS FLEX	3 - ELBOW	4 - MUFFLER	5 - TURN DOWN	6 - V-CLAMP
STYLE 1	82CTURBO1	82CFLEX18OD	N/R	C-0010	TD400	82VCLT
STYLE 2	82CTURBO2	82CFLEX28	82CNAEL	C-0010	TD400	82VCLT

ACCESSORIES

MUFFLER HANGER



GM OV STRAP

TUBE HANGER

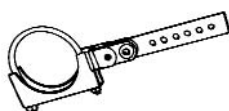

GMHGR4

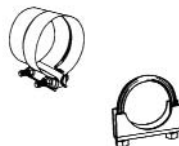

CLAMPS

A(3'')
300SCPF

B(4'')
400SCPF

U-400

AUTO-JET MUFFLER CORP.

U.S. toll free 1-800-247-5391 • Fax 515-224-0727 • website: www.auto-jet.com
 Canada toll free 1-866-229-3402 • Fax 519-455-1103 • website: www.unitedmuffler.com

GM 6

CHEVROLET/GMC

1979-86 GMC TOPKICK OR CHEV. KODIAK WITH CAT. 3208 ENGINES

2-PIECE Y & CROSSOVER

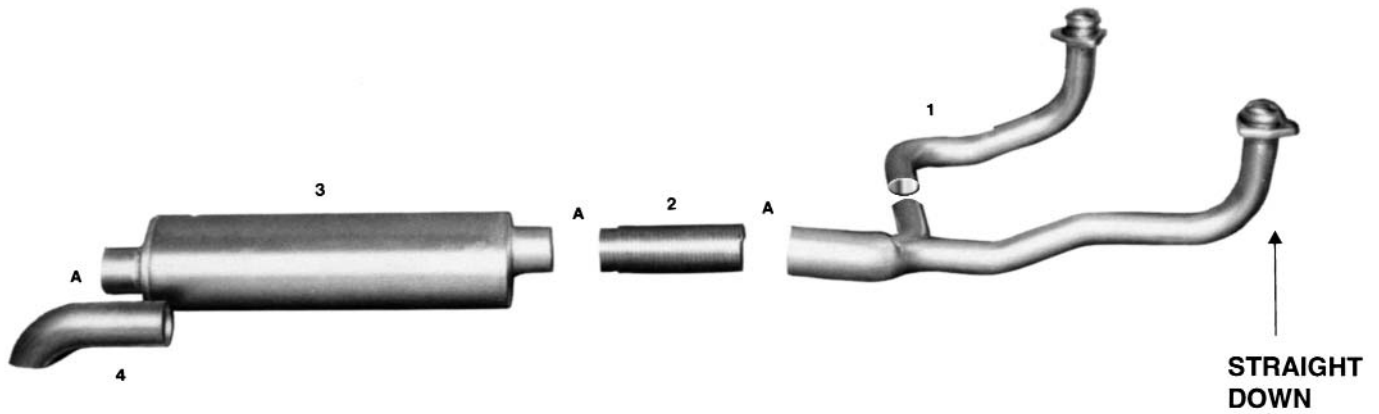

1 - MANIFOLD PIPE	2 - FLEX	3 - MUFFLER	4 - TURN DOWN
GM 320879S	FLEX40024OD	C-0010	TD400

1983-UP MODELS C60, C70 WITH 3208 CAT. ENGINES

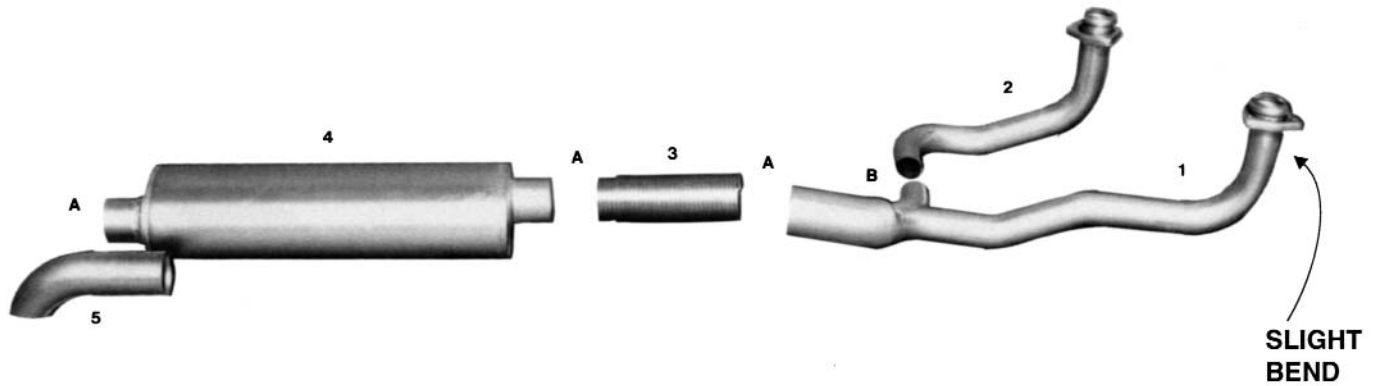

1 - EXHAUST PIPE RIGHT	2 - EXHAUST PIPE LEFT	3 - FLEX	4 - MUFFLER	5 - TURN DOWN
GM 3208Y83	GM 3208C083	FLEX40024OD	C-0010	TD400

ACCESSORIES

MUFFLER HANGER



GM OV STRAP

TUBE HANGER

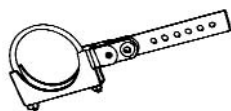

GMHGR4



CLAMPS

A(4")	B(2¾")
400SC[F	275SCPF
U-400	U-275

AUTO-JET MUFFLER CORP.

U.S. toll free 1-800-247-5391 • Fax 515-224-0727 • website: www.auto-jet.com
 Canada toll free 1-866-229-3402 • Fax 519-455-1103 • website: www.unitedmuffler.com

GM 7

CHEVROLET/GMC SERIES 50-60-70-80

1989-UP 8 CYL. W/366 C.I.D. (7.0L) T.B.I. ENG. W/CONVERTER

STAINLESS STEEL SYSTEM

FOR SOLID STAINLESS
EXHAUST RINGS SEE ACC 13
"WILL NOT BLOW OUT"

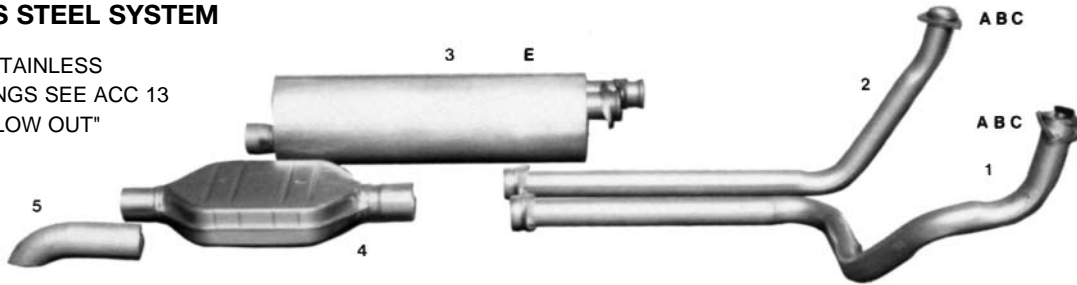

	1 - RIGHT MANIFOLD PIPE	2 - LEFT MANIFOLD PIPE	3 - MUFFLER	4 - CONVERTER	5 - TURN DOWN
1989-91	TBIRM	TBILM	2-250300BS	GMCONV	TD300
1992-97	CV366R	CV366L	2-250300BS	GMCONV	TD300

1986-90 8 CYL. W/366, 427 C.I.D.

STAINLESS STEEL SYSTEM

FOR SOLID STAINLESS
EXHAUST RINGS SEE ACC 13
"WILL NOT BLOW OUT"

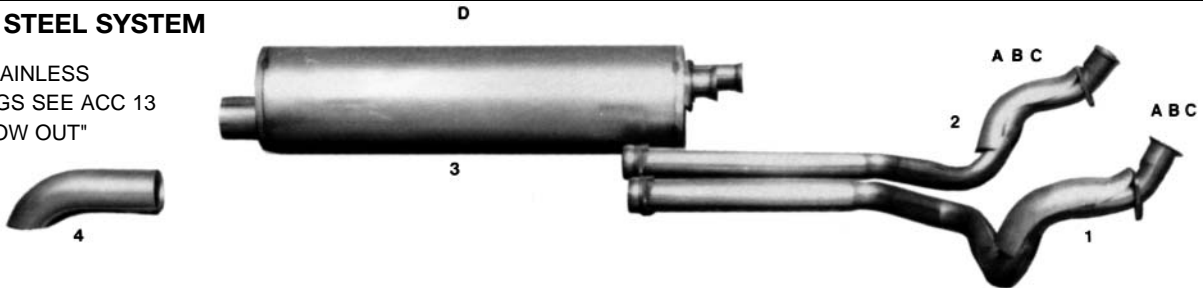

	1 - RIGHT MANIFOLD PIPE	2 - LEFT MANIFOLD PIPE	3 - MUFFLER	4 - TURN DOWN
	366SSR6	366SSL6	2-250400BS	TD400

1985-UP 8 CYL. W/366, 427 C.I.D. - 4 BBL ENG. WITH TWO MUFFLERS

STAINLESS STEEL SYSTEM

FOR SOLID STAINLESS
EXHAUST RINGS SEE ACC 13
"WILL NOT BLOW OUT"

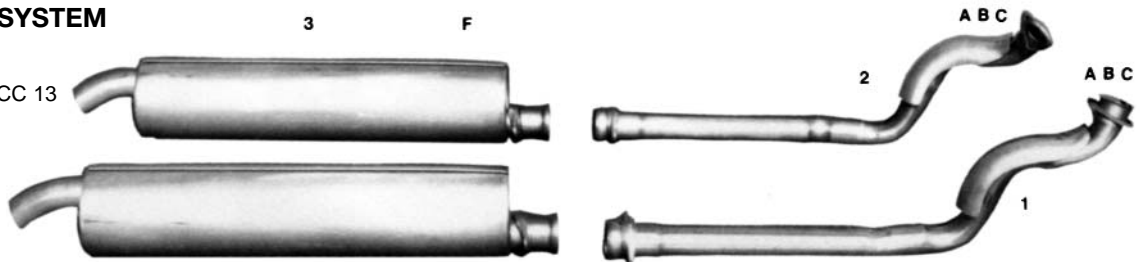

1 - RIGHT MANIFOLD PIPE	2 - LEFT MANIFOLD PIPE	3 - MUFFLER
366SSR5	366SSL5	68486L

ACCESSORIES

EXHAUST RING



366ERSS

SPRINGS



SPRINGSS

STUDS



STUDSS

MUFFLER HANGERS



GM10MH



GM875MH



GM7MH

AUTO-JET MUFFLER CORP.

U.S. toll free 1-800-247-5391 • Fax 515-224-0727 • website: www.auto-jet.com

Canada toll free 1-866-229-3402 • Fax 519-455-1103 • website: www.unitedmuffler.com

GM 8

CHEVROLET/GMC SERIES 50-60-70-80

1980-90 8 CVL. W/366, 427 C.I.D. (BALL & SOCKET JOINT)

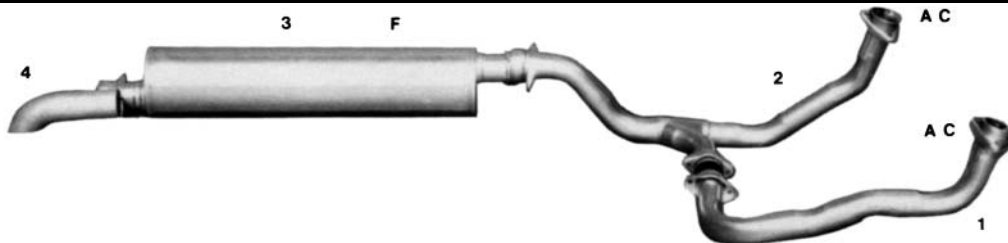

	1 - RIGHT MANIFOLD PIPE	2 - LEFT MANIFOLD PIPE	3 - MUFFLER	4 - TURN DOWN
JOIN BEHIND CROSSMEMBER	366LCOB	366LYB	275275BTD	TD275
JOIN IN FRONT OF CROSSMEMBER	366LCOF	366LYF	275275BTD	TD275

1979-90 8 CYL. W/366, 427 C.I.D. (CLAMP JOINT)

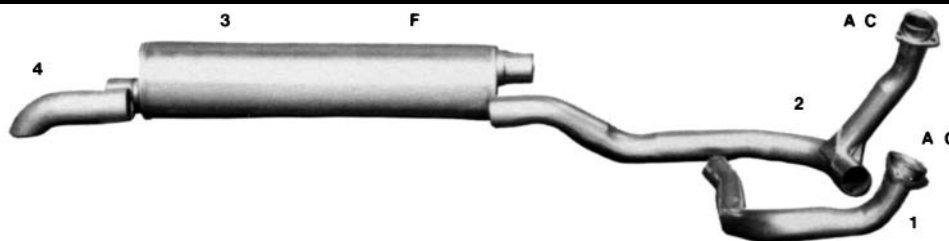

	1 - RIGHT MANIFOLD PIPE	2 - LEFT MANIFOLD PIPE	3 - MUFFLER	4 - TURN DOWN
AUTO TRANSMISSION	366ECO A	366EY A	7-0030	TD275
STANDARD TRANSMISSION	366ECO S	366EY S	7-0030	TD275

1985-UP 8 CYL. W/350 C.I.D.

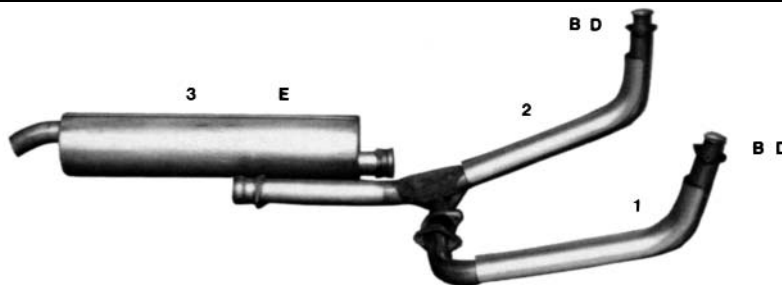

1 - RIGHT MANIFOLD PIPE	2 - LEFT MANIFOLD PIPE	3 - MUFFLER
350LCOSS	350LYSS	68486L

ACCESSORIES

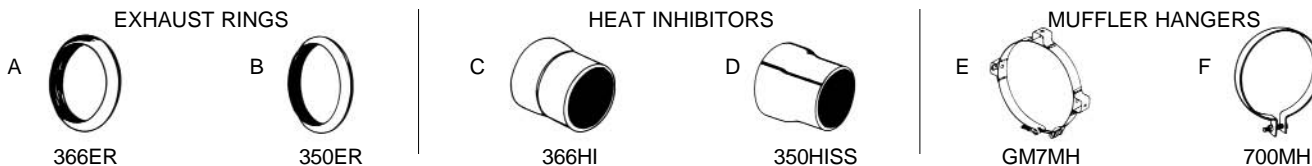

AUTO-JET MUFFLER CORP.

U.S. toll free 1-800-247-5391 • Fax 515-224-0727 • website: www.auto-jet.com
 Canada toll free 1-866-229-3402 • Fax 519-455-1103 • website: www.unitedmuffler.com

CHEVROLET - GMC VAN EXHAUST SYSTEM

1998-UP G-SERIES VAN, 6.5 LITRE DIESEL TURBO PIPE WITH CONVERTER



SEE BELOW FOR
MUFFLER AND
TAILPIPES

PART # 65GCONVT
GASKET PART # GMGS3HOLE

G-30 & G-3500 SERIES, 6.5L DIESEL MUFFLER & TAILPIPES

BELLOWS OPTIONAL

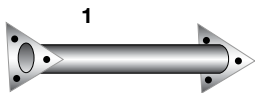

NOTE: Muffler has
3-hole inlet.

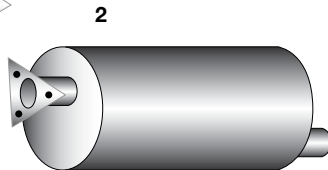

NOTE: Original
Equipment has 3-hole
flanges connecting the
extension pipe to the
muffler. Auto-Jet is slip fit.
Flanged Connection is available.

3 - SPECIFY RIGHT SIDE OR REAR EXIT

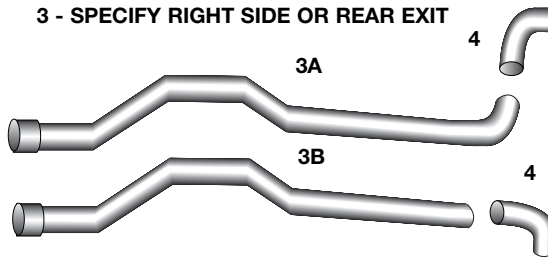

OE # 15739326 MUFFLER AND TAIL PIPE WELDED ASSEMBLY.

DESCRIPTION	1 - FRONT EXTENSION	2 - MUFFLER	3 - TAIL PIPE		4 - TURNOUT
			A - RIGHT SIDE EXIT	B - REAR EXIT	
PART #	65GEXTFL	65G300FL	65G275TPRH	65G275TPOR	TD275

AUTO-JET MUFFLER CORP.

U.S. toll free 1-800-247-5391 • Fax 515-224-0727 • website: www.auto-jet.com
Canada toll free 1-866-229-3402 • Fax 519-455-1103 • website: www.unitedmuffler.com

GM 10

CHEV./GMC CUTAWAY VAN EXHAUST SYSTEMS

1998-UP G-30 & G-3500 SERIES VAN, 350 C.I.

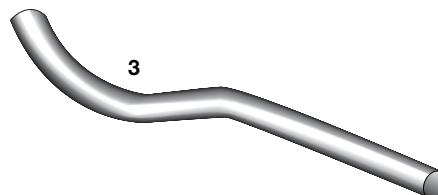
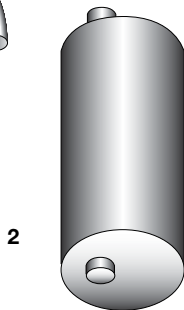
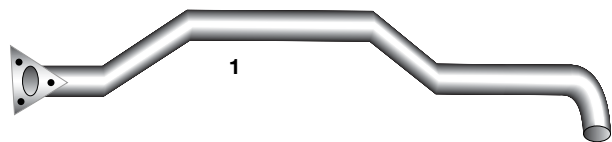

EXTENSION PIPE, MUFFLER & TAIL PIPE
OE WELDED ASSEMBLY
OE # 15734043
MODEL: CUT AWAY VAN

MUFFLER SITS CROSS-WAYS

DESCRIPTION	1 - EXTENSION PIPE	2 - MUFFLER	3 - TAIL PIPE
PART #	G30SAVEXT	G30SAV300	G30SAVTP

1994-UP G-30 & G-3500 SERIES, 6.5L DIESEL

SPECIFY WHEEL BASE 125" OR 146"
EXHAUST RING: #GM62ER
146" W.B. EXTENSION PART# 300EXT

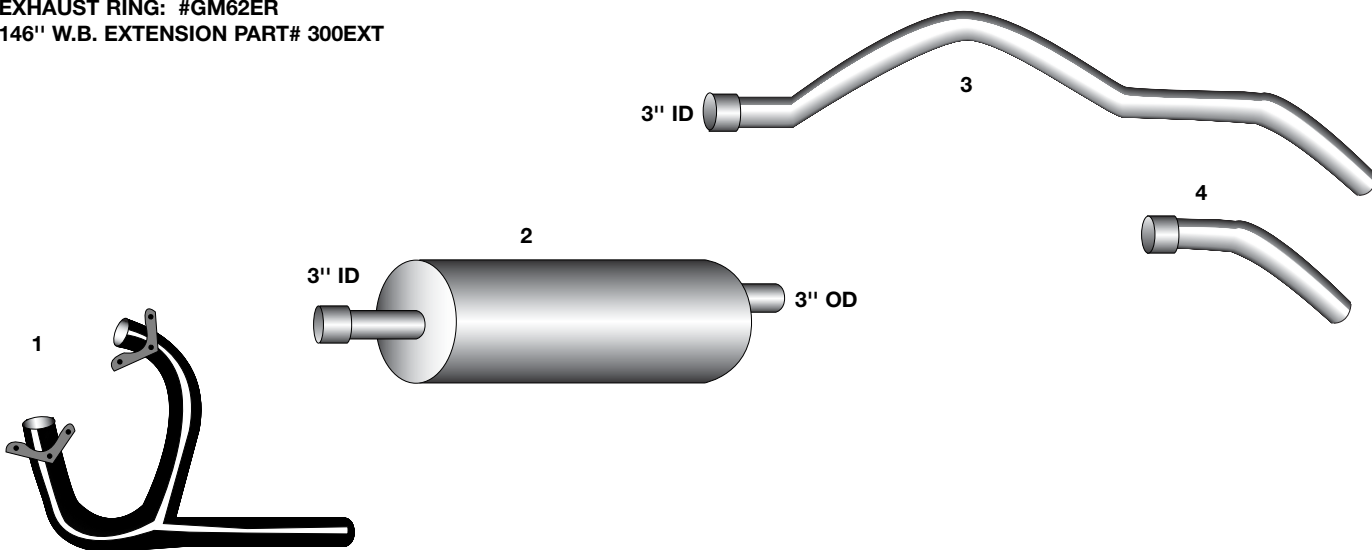

STAINLESS STEEL

DESCRIPTION	1 - MANIFOLD PIPE	2 - MUFFLER	3 - TAIL PIPE	4 - WIDE BODY EXTENSION
PART #	65GYSS	GM65300G	GMGTP92	WBEXT92

AUTO-JET MUFFLER CORP.

U.S. toll free 1-800-247-5391 • Fax 515-224-0727 • website: www.auto-jet.com
Canada toll free 1-866-229-3402 • Fax 519-455-1103 • website: www.unitedmuffler.com

CHEVROLET/GMC MUFFLERS

END INLET - END OUTLET

AUTO-JET PART NO.: 275275B
APPLICATION: GAS
ENGINE: 350 C.I. - 366 C.I. - 427 C.I.
YEAR: 1979 TO 1984

2-3/4" BALL
CONNECTION OUTLET -
OFFSET

7"
ROUND

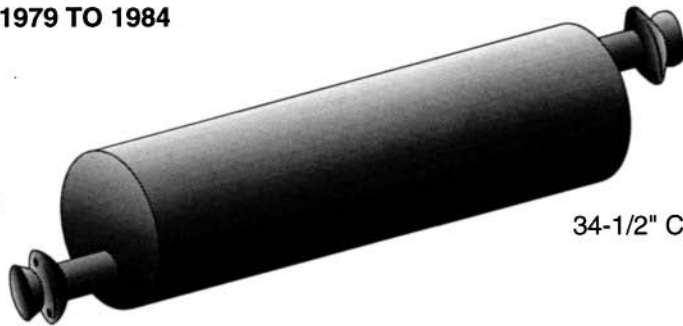

34-1/2" CASE

2-3/4" SOCKET CONNECTION INLET - OFFSET

MUFFLER HANGER



#700MH

AUTO-JET PART NO.: 10-0050
APPLICATION: DIESEL
ENGINE: 3116 CAT.
YEAR: 1992 & UP

4" CENTERED OUTLET

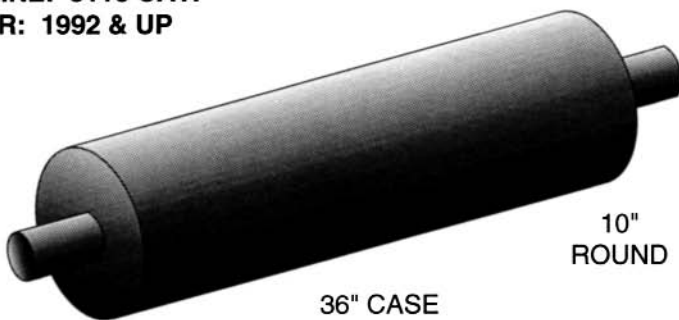

10"
ROUND

36" CASE

4" CENTERED INLET

MUFFLER HANGER

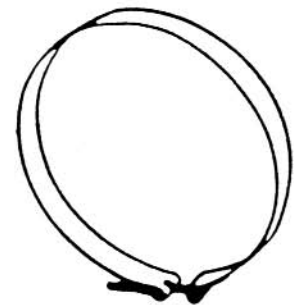

#GM10MH

AUTO-JET PART NO.: C-0020 NATURALLY ASP.
AUTO-JET PART NO.: C-0010 TURBO
APPLICATION: DIESEL
ENGINE: 8.2 LITRE
YEAR: 1980 TO 1990

4" OUTLET - OFFSET

8-1/4 X 11"
OVAL

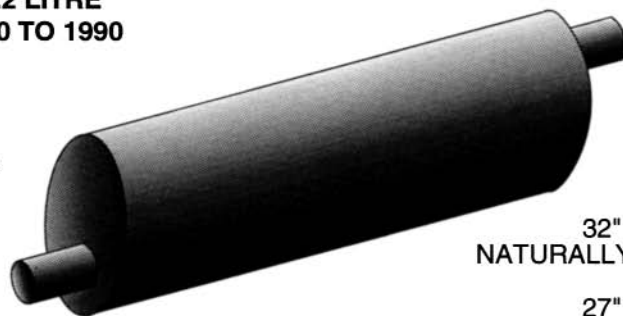

32" CASE
NATURALLY ASP.

27" CASE
TURBO

4" INLET - OFFSET

MUFFLER STRAP DIESEL



#GMOVSTRAP

AUTO-JET MUFFLER CORP.

U.S. toll free 1-800-247-5391 • Fax 515-224-0727 • website: www.auto-jet.com
Canada toll free 1-866-229-3402 • Fax 519-455-1103 • website: www.unitedmuffler.com

GM 12

CHEVROLET/GMC MUFFLERS

STAINLESS STEEL / END INLET - END OUTLET

AUTO-JET PART NO.: 2250400BS
APPLICATION: GAS
ENGINE: 366 C.I. - 427 C.I.
YEAR: 1986 TO 1989

4" OFFSET OUTLET

10"
ROUND

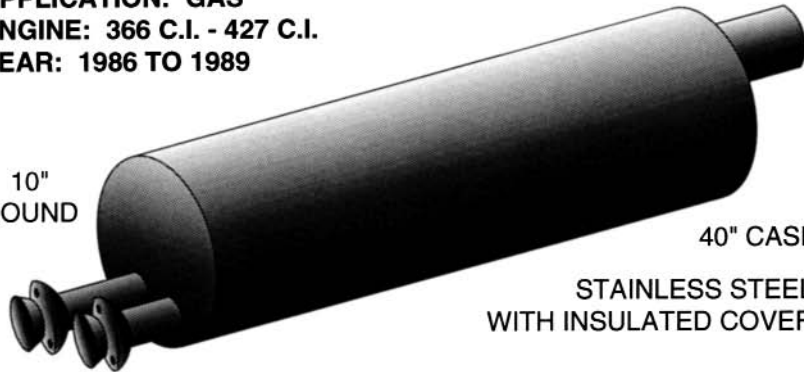

40" CASE

STAINLESS STEEL
WITH INSULATED COVER

DUAL INLETS - 2-1/2" SOCKET CONNECTION

**SHIELD
HANGER**



#GM10HS

**MUFFLER
HANGER**



#GM10MH

FRAME BRACKETS



FRONT
#GM10BRFT

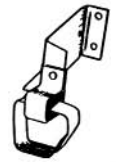

REAR
#GM10BRRE

AUTO-JET PART NO.: 2250300BS
APPLICATION: GAS
ENGINE: 366 C.I. - 427 C.I.
YEAR: 1989 & UP

3" OUT TO CONVERTER

8-3/4"
ROUND

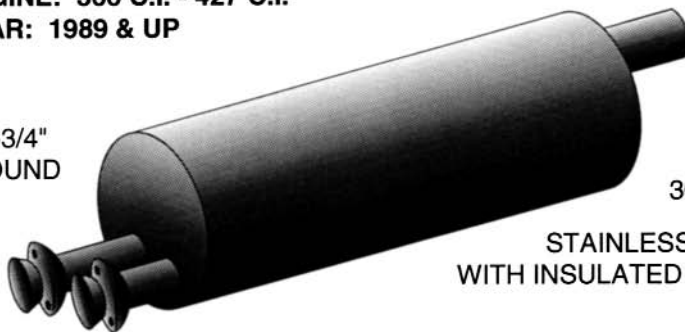

30" CASE

STAINLESS STEEL
WITH INSULATED COVER

DUAL INLETS - 2-1/2" SOCKET CONNECTION

MUFFLER HANGER

#GM875MH



BRACKETS



MUFFLER
#GM875BR



FRAME
#GM875FRBR

AUTO-JET PART NO.: 275275BS
APPLICATION: GAS
ENGINE: 350 C.I., 366-427 C.I.
YEAR: 350 C.I. - 1985 & UP
 366-427 C.I. 1985 & 1986

2-3/4" BALL
CONNECTION OUTLET -
OFFSET

7"
ROUND

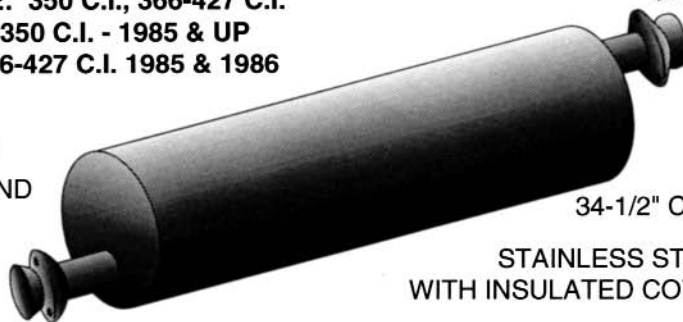

34-1/2" CASE

STAINLESS STEEL
WITH INSULATED COVER

2-3/4" SOCKET CONNECTION INLET - OFFSET

SHIELD



1985 & UP 350 C.I.,
1985 & 1986 366-427 C.I.
WITH TWO MUFFLERS

#GM7SHLD

MUFFLER HANGER

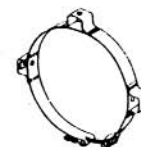

#GM7MH

AUTO-JET MUFFLER CORP.

U.S. toll free 1-800-247-5391 • Fax 515-224-0727 • website: www.auto-jet.com
 Canada toll free 1-866-229-3402 • Fax 519-455-1103 • website: www.unitedmuffler.com

GM 13

CHEVROLET/GMC MUFFLERS



END INLET - SIDE OUTLET

AUTO-JET PART NO.: S-198-92
SIDE OUTLET
 GM Part No. 15552515

19" FROM EDGE OF CASE
 TO OUTLET

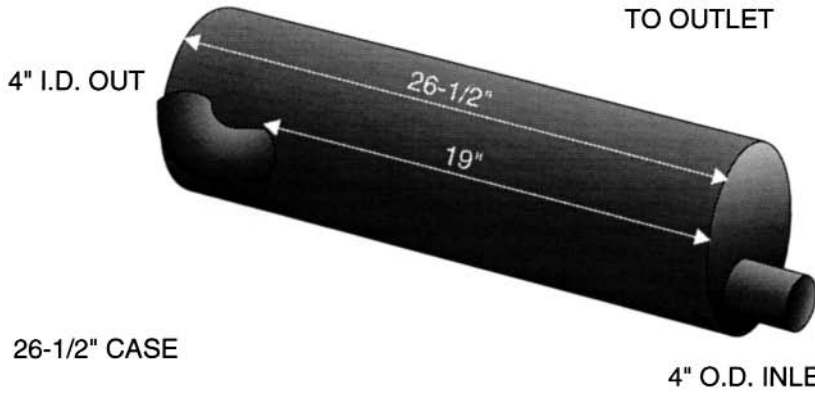

INLET END VIEW

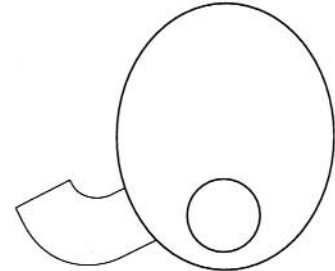

AUTO-JET PART NO.: S-247-92
SIDE OUTLET
 GM Part No. 15504836

7" FROM BACK OF CASE
 TO CENTER OF OUTLET

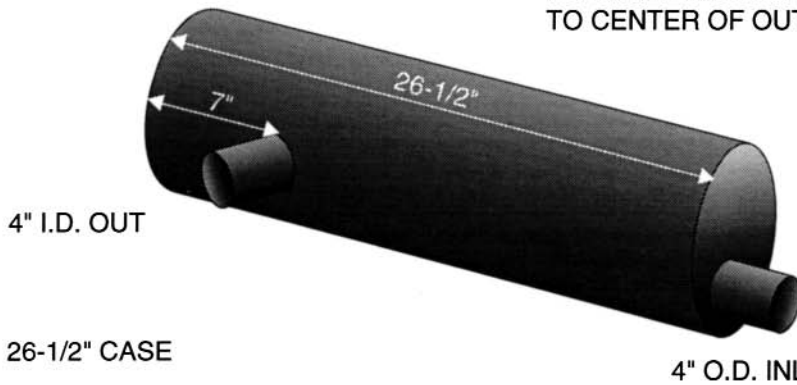

INLET END VIEW

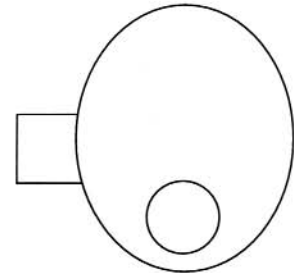

AUTO-JET PART NO.: S-243-92
SIDE OUTLET
 GM Part No. 2005719

5" FROM BACK OF CASE
 TO CENTER OF OUTLET

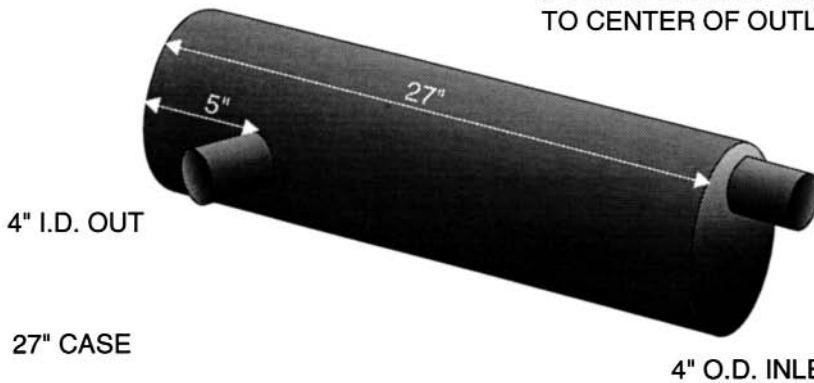

INLET END VIEW

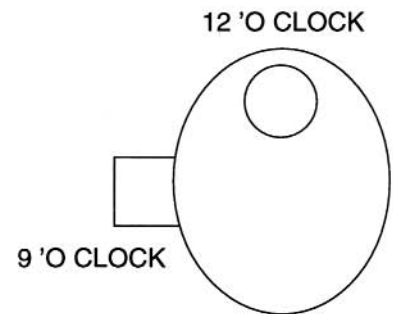

AUTO-JET MUFFLER CORP.

U.S. toll free 1-800-247-5391 • Fax 515-224-0727 • website: www.auto-jet.com
 Canada toll free 1-866-229-3402 • Fax 519-455-1103 • website: www.unitedmuffler.com



CHEVROLET/GMC

MISCELLANEOUS MUFFLERS

AUTO-JET PART NO.: 59786L
SIDE
OUTLET

12" FROM
 INLET END OF CASE
 TO CENTER OF OUTLET

INLET END VIEW

12 O'CLOCK

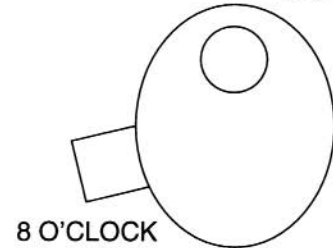
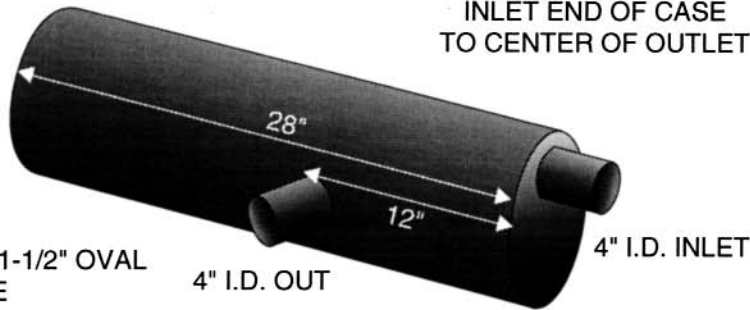

8-1/4 X 11-1/2" OVAL

8-1/4 X 11-1/2" OVAL
 28" CASE

4" I.D. OUT

4" I.D. INLET

AUTO-JET PART NO.: 72486L
TOP INLET - END OUTLET
ENGINE: 3116 CAT.,
KODIAK & TOPKICK

4-1/4" FROM
 END OF CASE
 TO CENTER
 OF INLET

INLET END VIEW

12 O'CLOCK

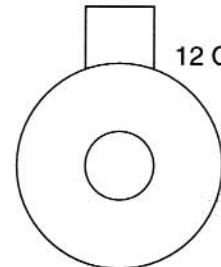
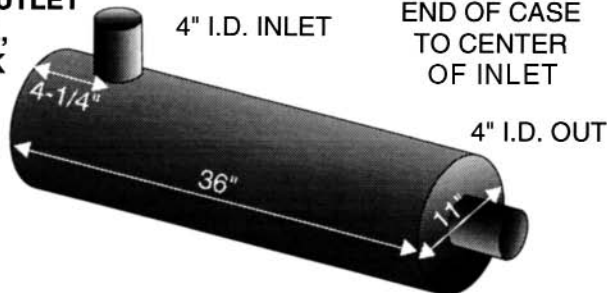

11" ROUND

GM Part No.
 15552174
 15609879

11" ROUND
 36" CASE

4" I.D. INLET

4" I.D. OUT

AUTO-JET PART NO.: CV400400
SIDE INLET - END OUTLET
APPLICATION: DIESEL
ENGINE: 3116 CAT.
YEAR: 1992 & UP

4-1/2" FROM
 END OF CASE
 TO CENTER OF INLET

MUFFLER HANGER



#GM875MH

4" CENTERED OUTLET

9" ROUND
 42" CASE

4" SIDE INLET

CHEVROLET/GMC TILTMASTER - ISUZU

AUTO-JET PART NO.: 69086L
END INLET - END OUTLET
HEAVY DUTY

Fits 86-90 Chev./GMC
 6 cyl. W6, W7 Tiltmaster
 and 86-90 Isuzu Trk.
 6 cyl. FSR, FTR, FVR, EVR
 GM Part No. 9404 4319
 9404 7627

INLET END VIEW

3-3/16" I.D.
 OUTLET

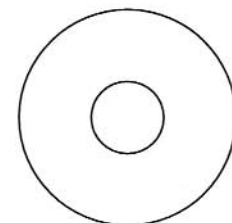
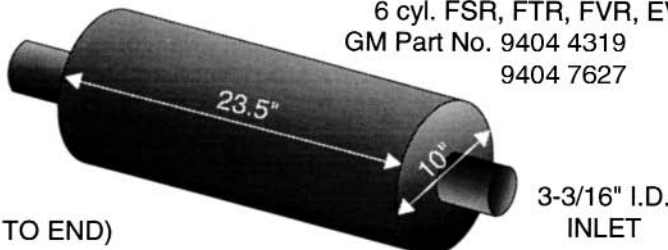

10" ROUND

10" ROUND
 23.5" CASE
 (28-5/8" END TO END)

3-3/16" I.D.
 INLET

AUTO-JET MUFFLER CORP.

U.S. toll free 1-800-247-5391 • Fax 515-224-0727 • website: www.auto-jet.com
 Canada toll free 1-866-229-3402 • Fax 519-455-1103 • website: www.unitedmuffler.com

TOP INLET - SIDE OUTLET

AUTO-JET PART NO.: 86756
TOP INLET - SIDE OUTLET
GM# 15628117

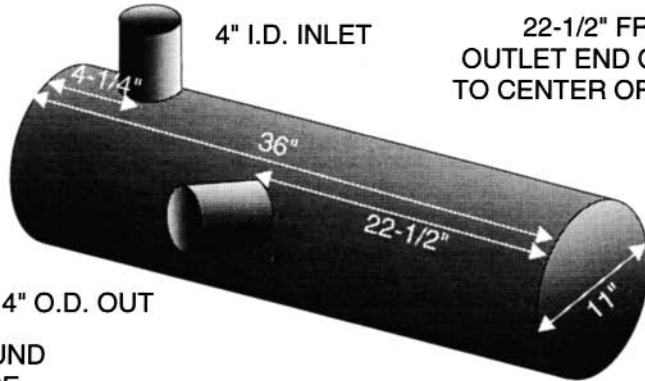

11" ROUND
36" CASE

4-1/4" FROM
INLET END OF CASE
TO CENTER OF INLET

22-1/2" FROM
OUTLET END OF CASE
TO CENTER OF OUTLET

INLET END VIEW

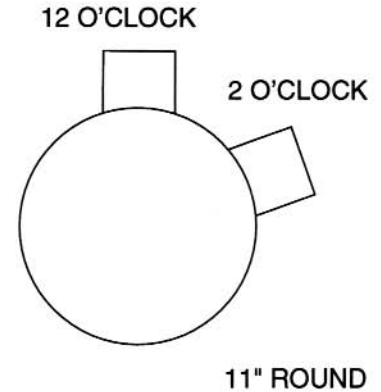

AUTO-JET PART NO.: 86727
TOP INLET - SIDE OUTLET
GM# 15572772
& 15572771

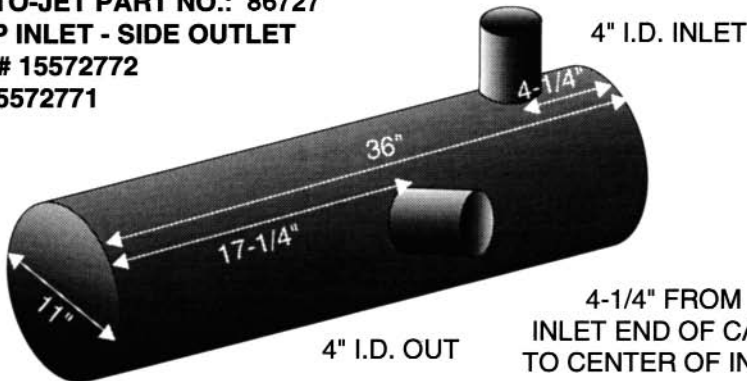

11" ROUND
36" CASE

4-1/4" FROM
INLET END OF CASE
TO CENTER OF INLET

17-1/4" FROM
OUTLET END OF CASE
TO CENTER OF OUTLET

INLET END VIEW

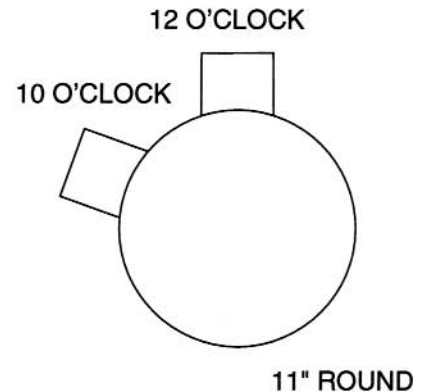

AUTO-JET PART NO.: 86725
TOP INLET - SIDE OUTLET
GM# 15658354

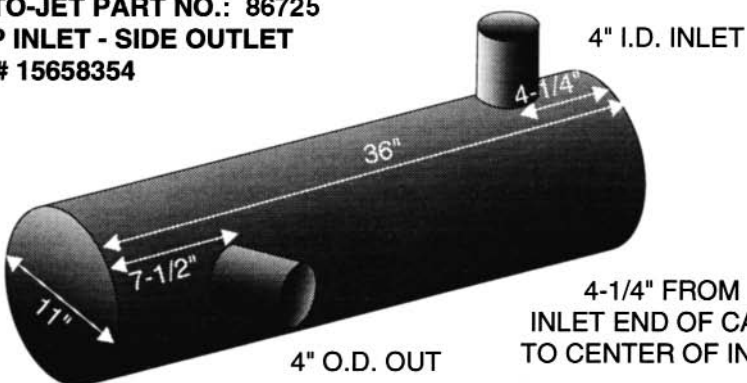

11" ROUND
36" CASE

4-1/4" FROM
INLET END OF CASE
TO CENTER OF INLET

7-1/2" FROM
OUTLET END OF CASE
TO CENTER OF OUTLET

INLET END VIEW

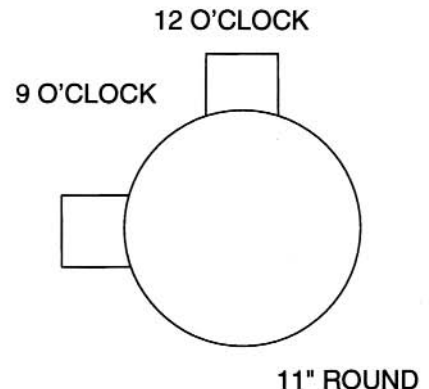

AUTO-JET MUFFLER CORP.

U.S. toll free 1-800-247-5391 • Fax 515-224-0727 • website: www.auto-jet.com
Canada toll free 1-866-229-3402 • Fax 519-455-1103 • website: www.unitedmuffler.com